

LES ANNÉES ART NOUVEAU

Les bâtiments

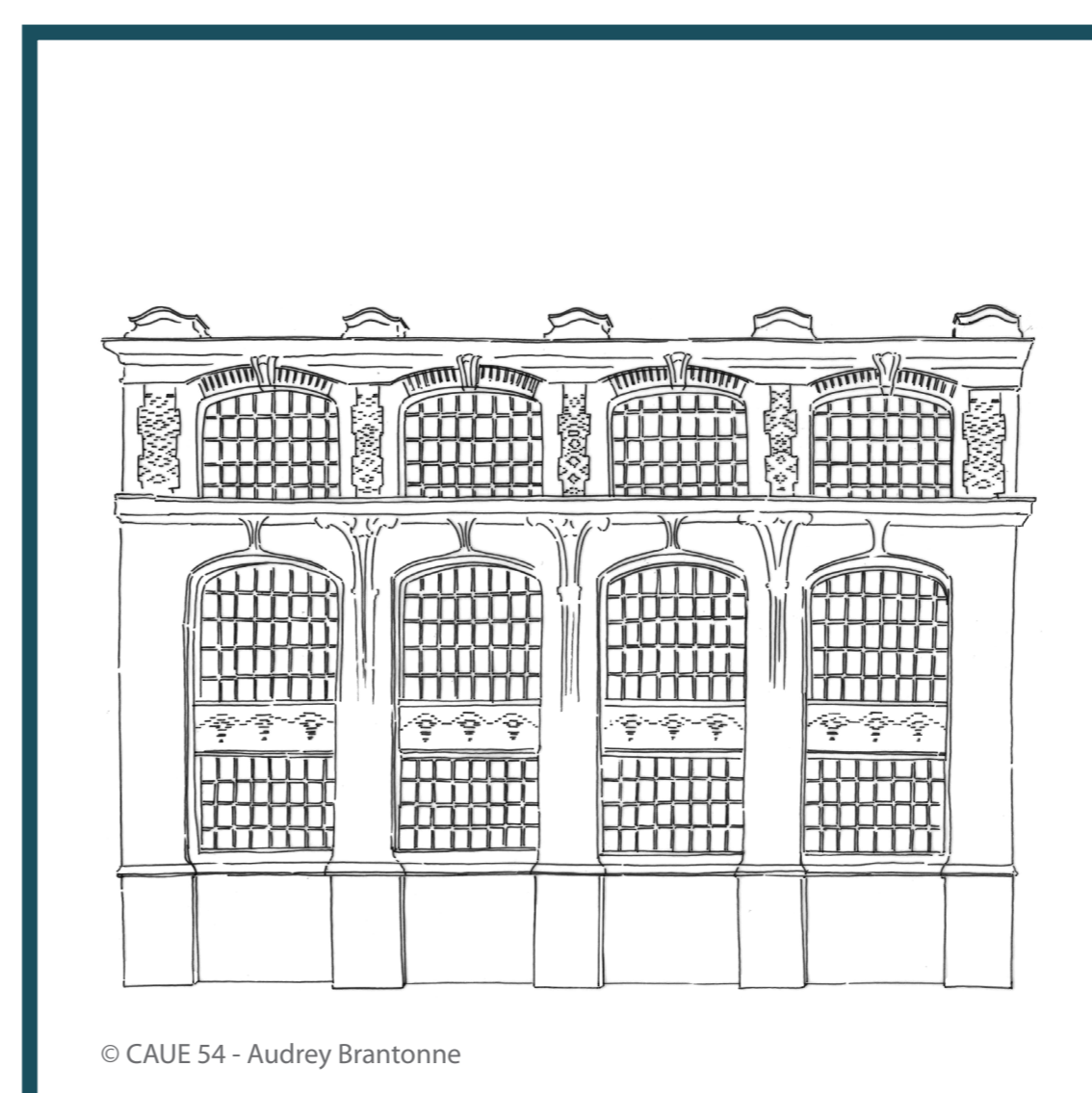
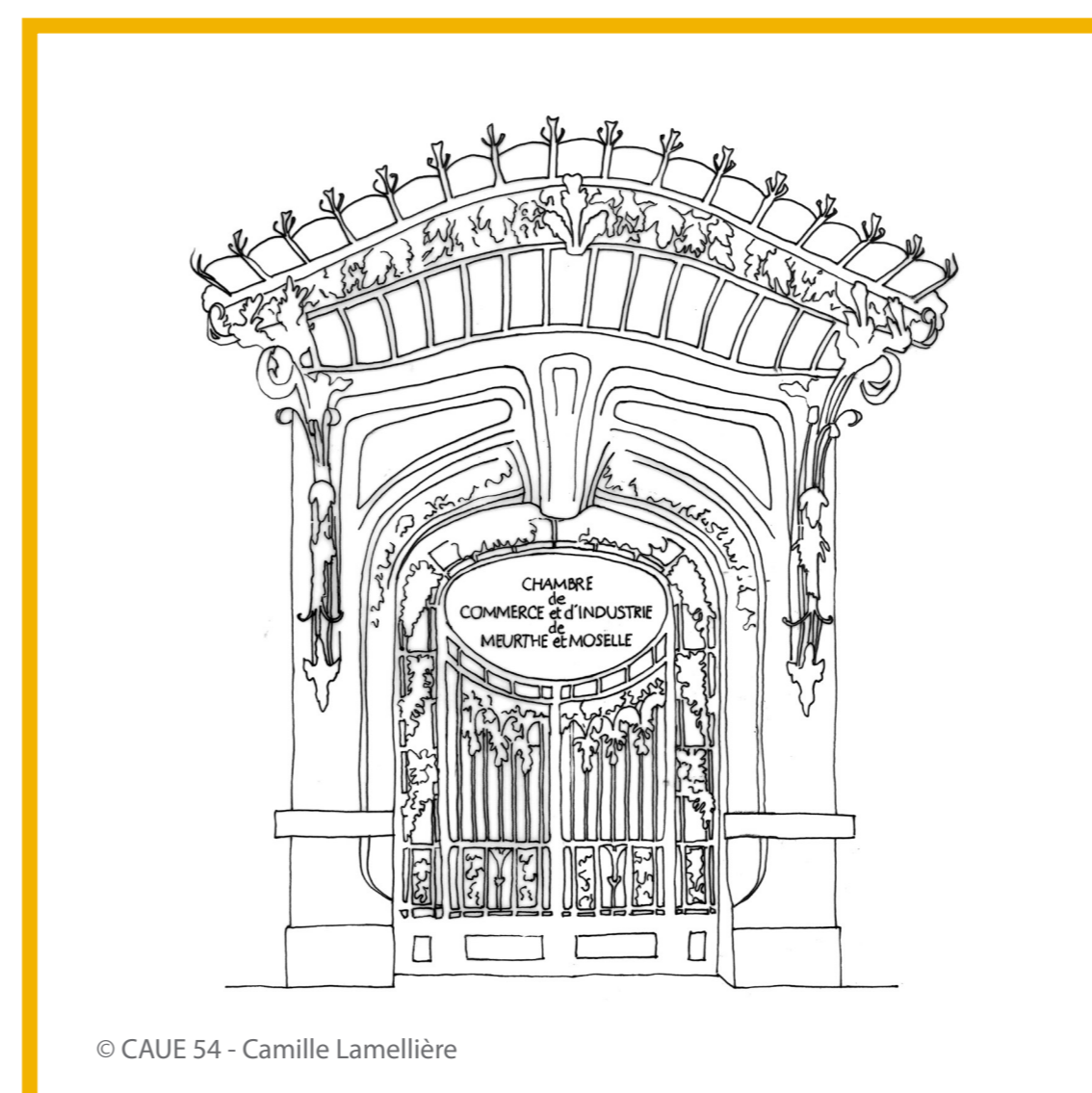
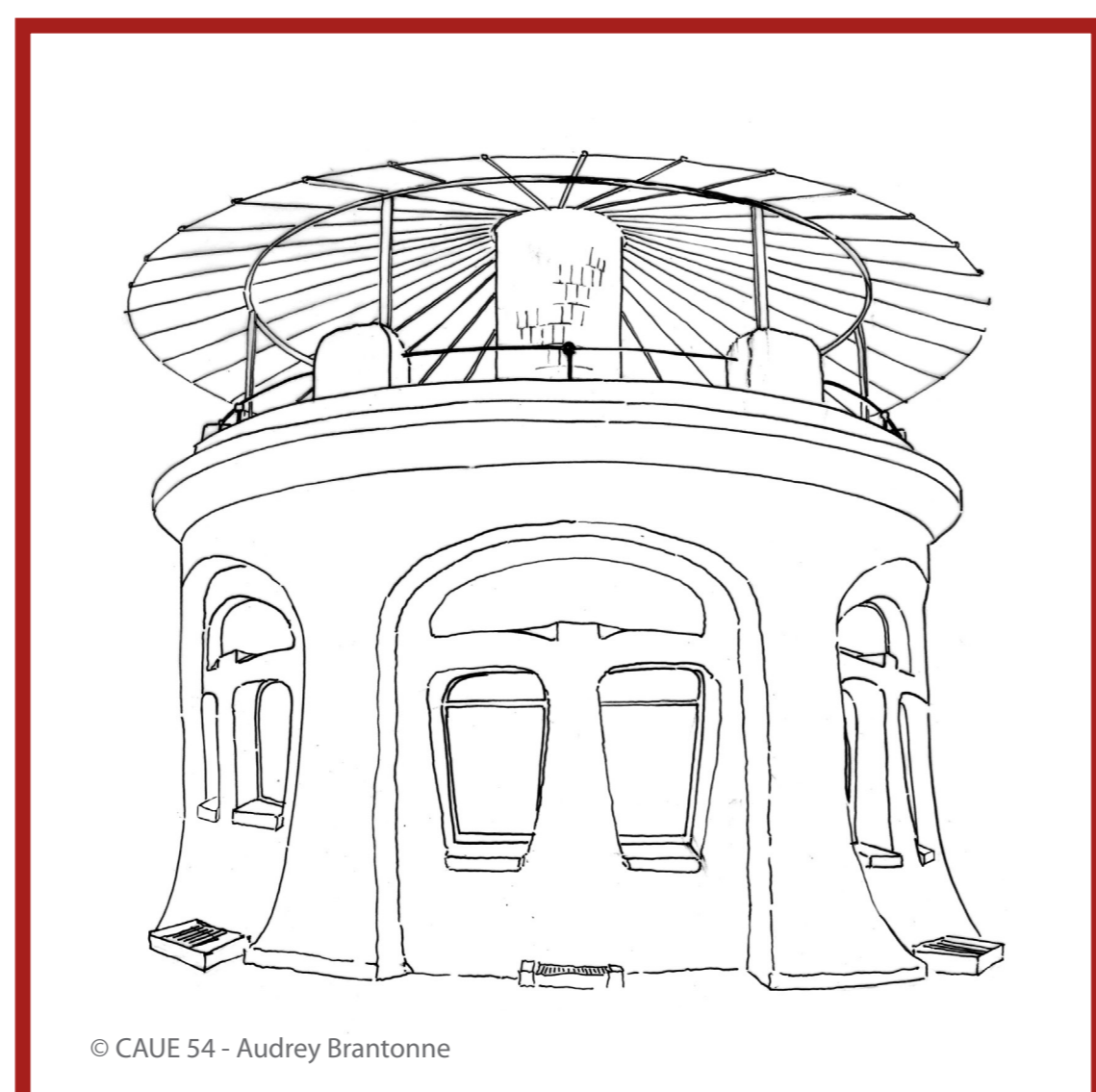

Les caractéristiques de la période

MAISONS
BOURGEOISES

ARTISANAT, ART
ET INDUSTRIE

ÉCOLE DE NANCY

LIGNES COURBES

INSPIRÉ DE LA
NATURE

ART TOTAL

1890

1900

LA PREMIÈRE RECONSTRUCTION

Les bâtiments

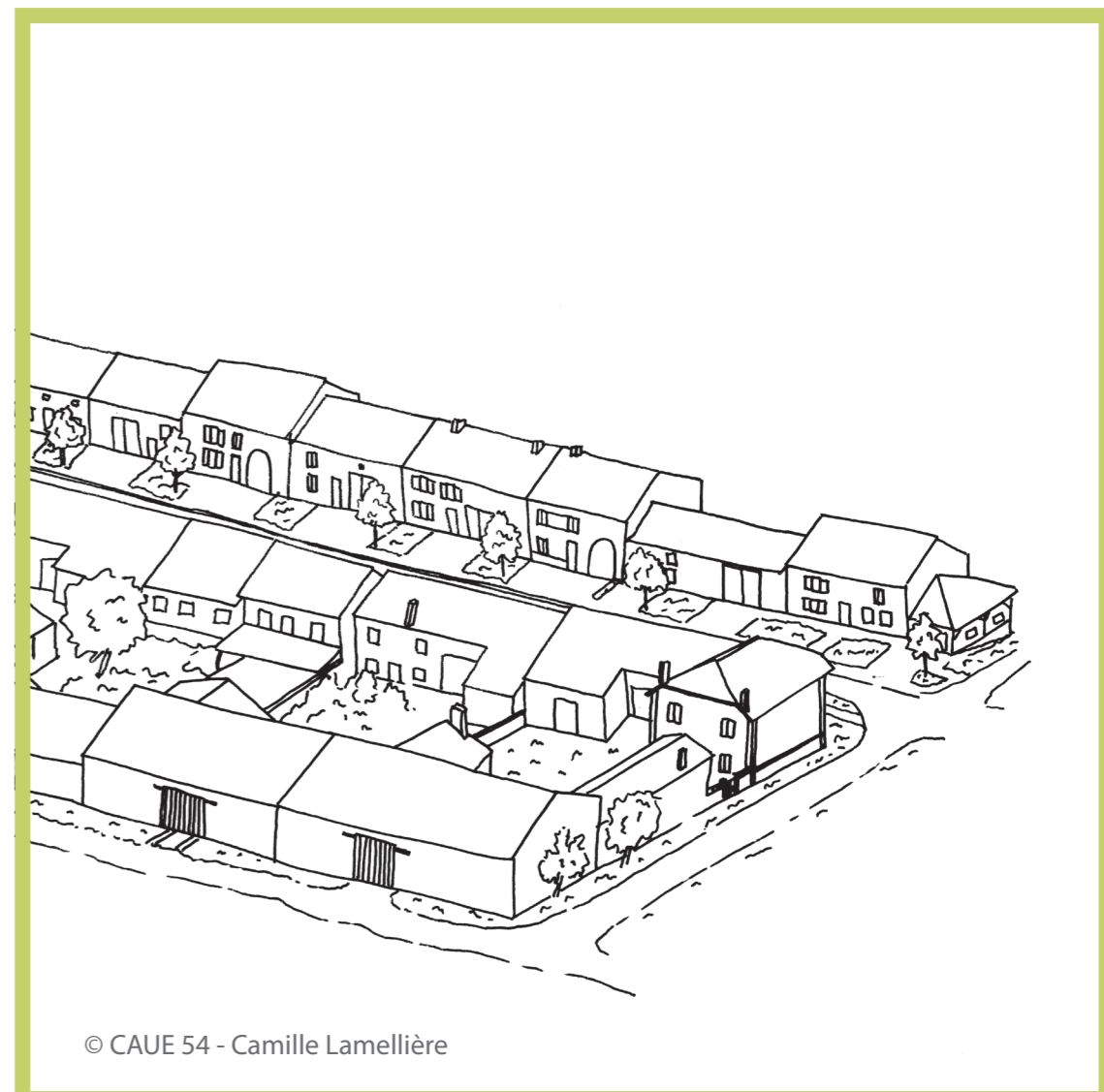

Les caractéristiques de la période

CITÉ-JARDIN

MATÉRIAUX
TRADITIONNELS

HYGIÉNISME

MAIRIE-ÉCOLE

RÉGIONALISME

1910

1920

1^{ÈRE} GUERRE
MONDIALE

AU

LES ANNÉES ART DÉCO

Les bâtiments

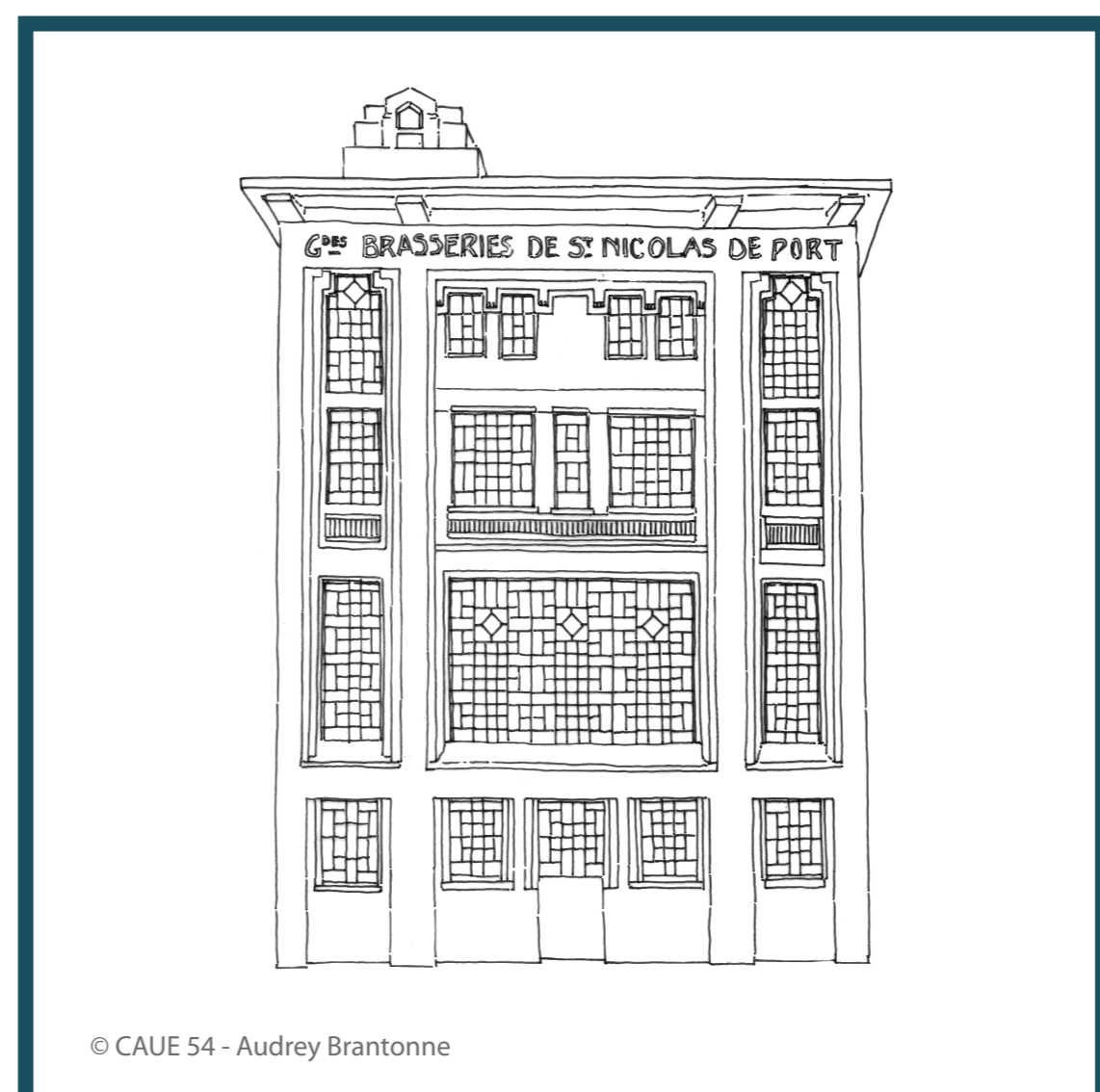

Les caractéristiques de la période

FORMES
GÉOMÉTRIQUES

DÉCOR

HABITATIONS À
BON MARCHÉ

ART TOTAL

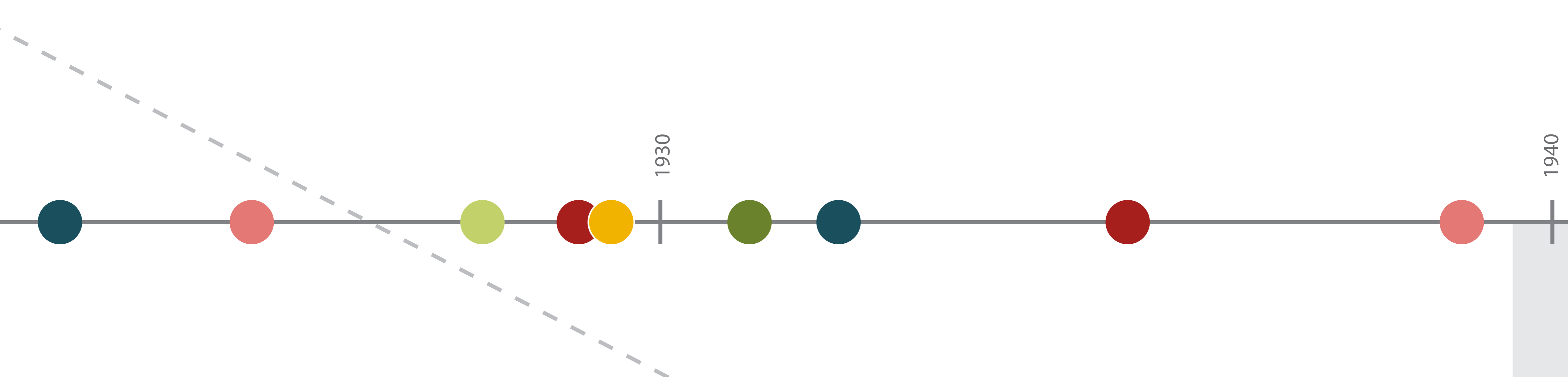

PREMIÈRE RECONSTRUCTION

ART DÉCO

SECONDE RECONSTRUCTION ET EXPÉRIMENTATIONS

Les bâtiments

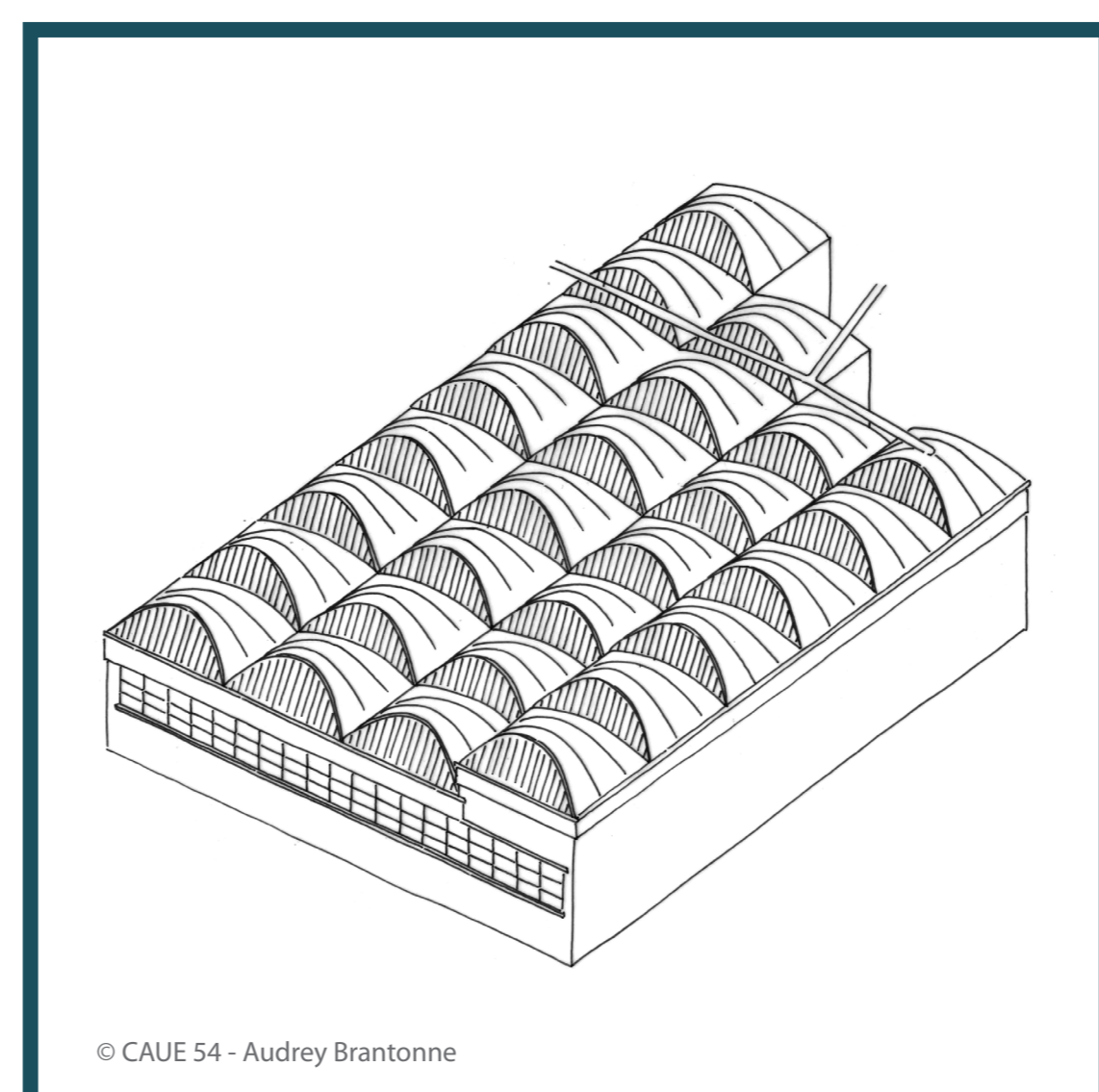
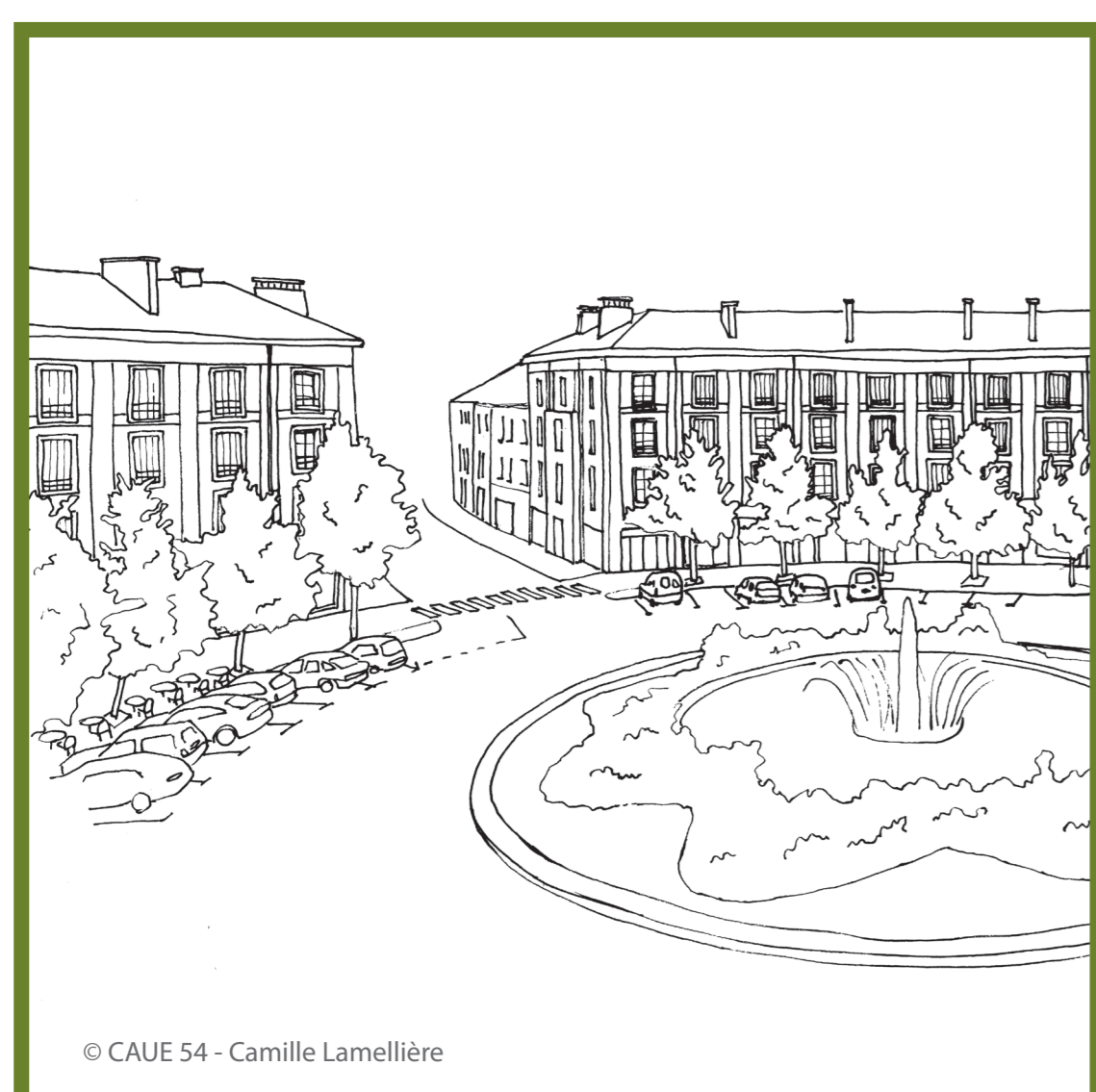
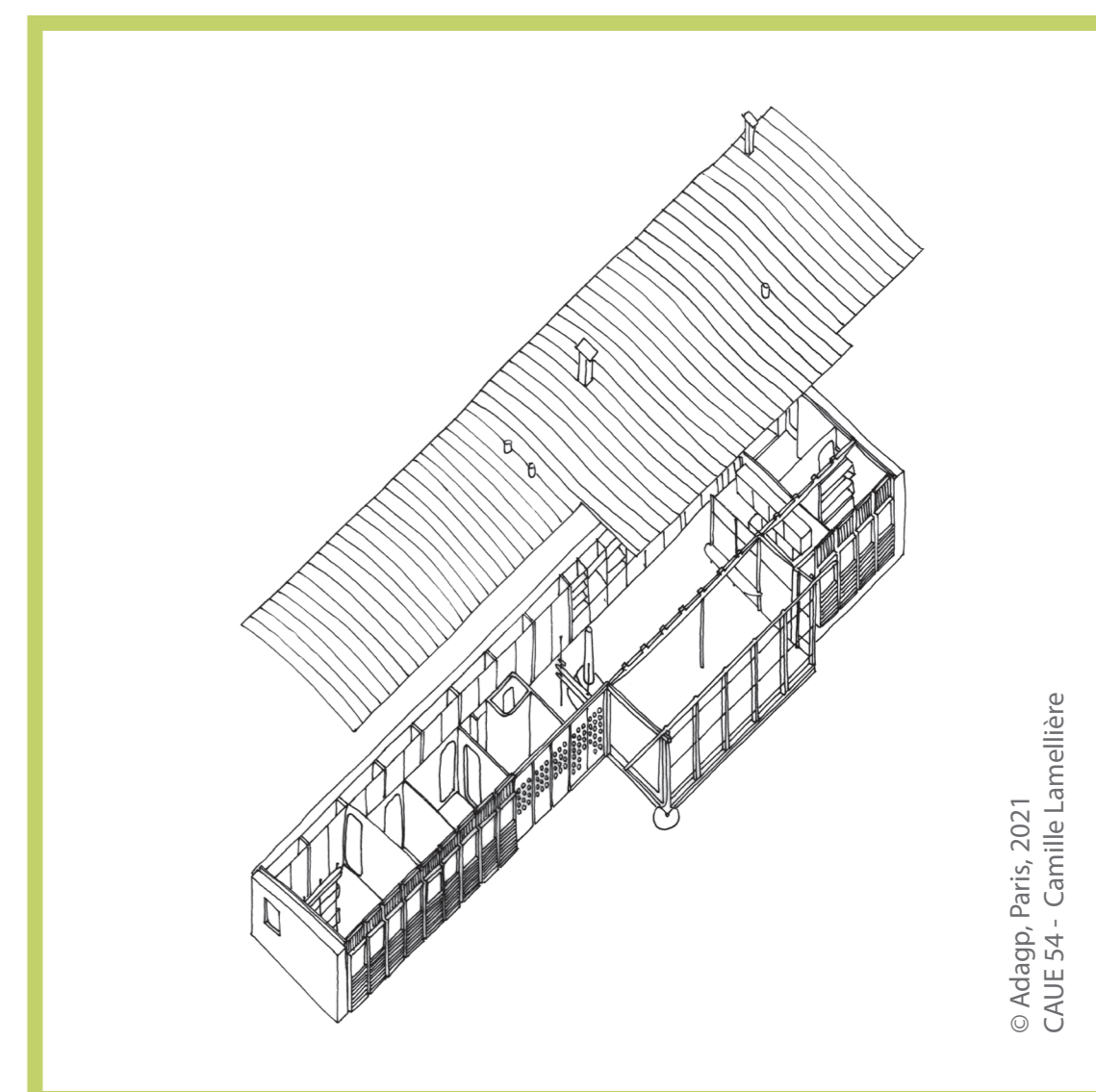
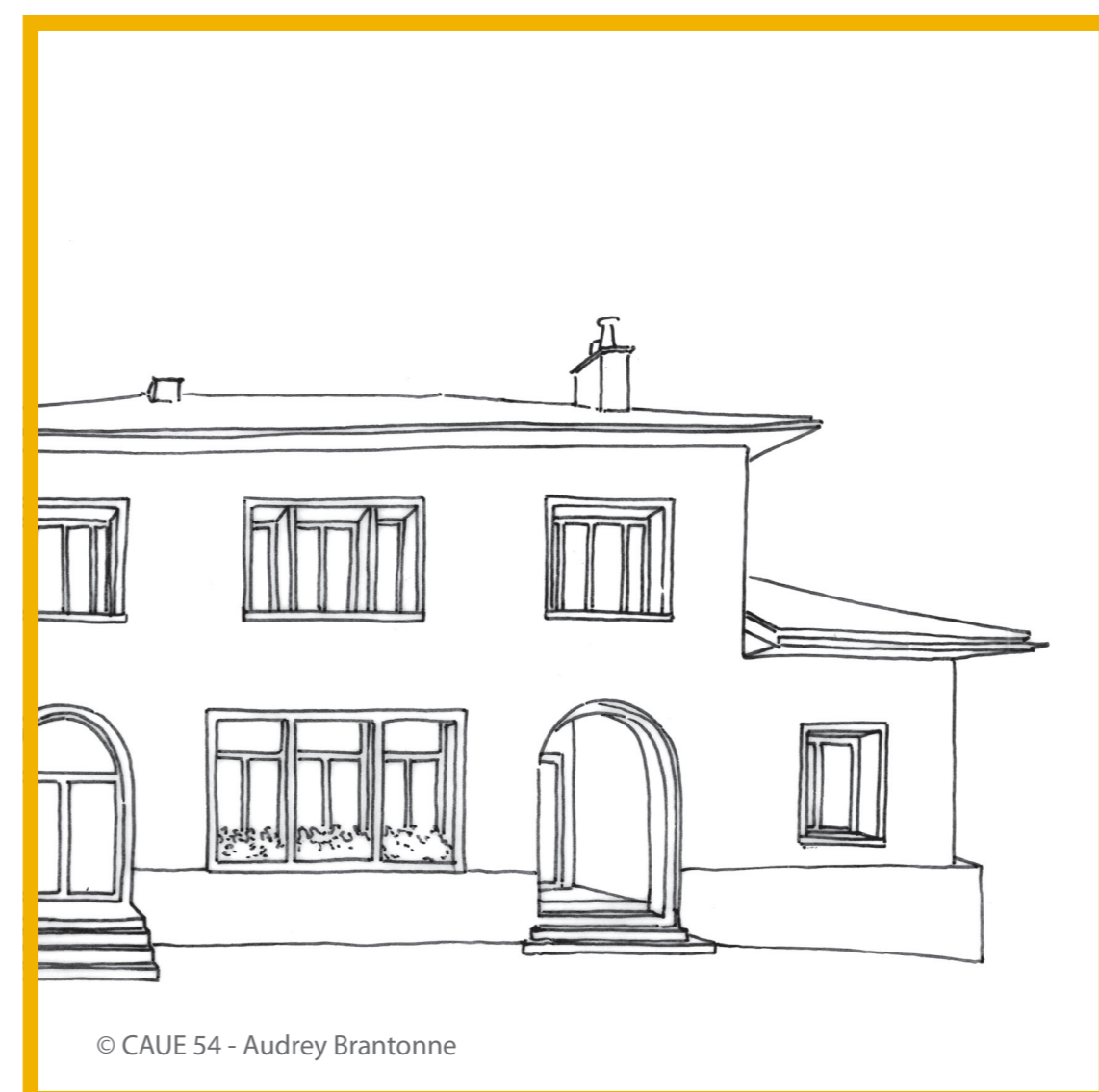
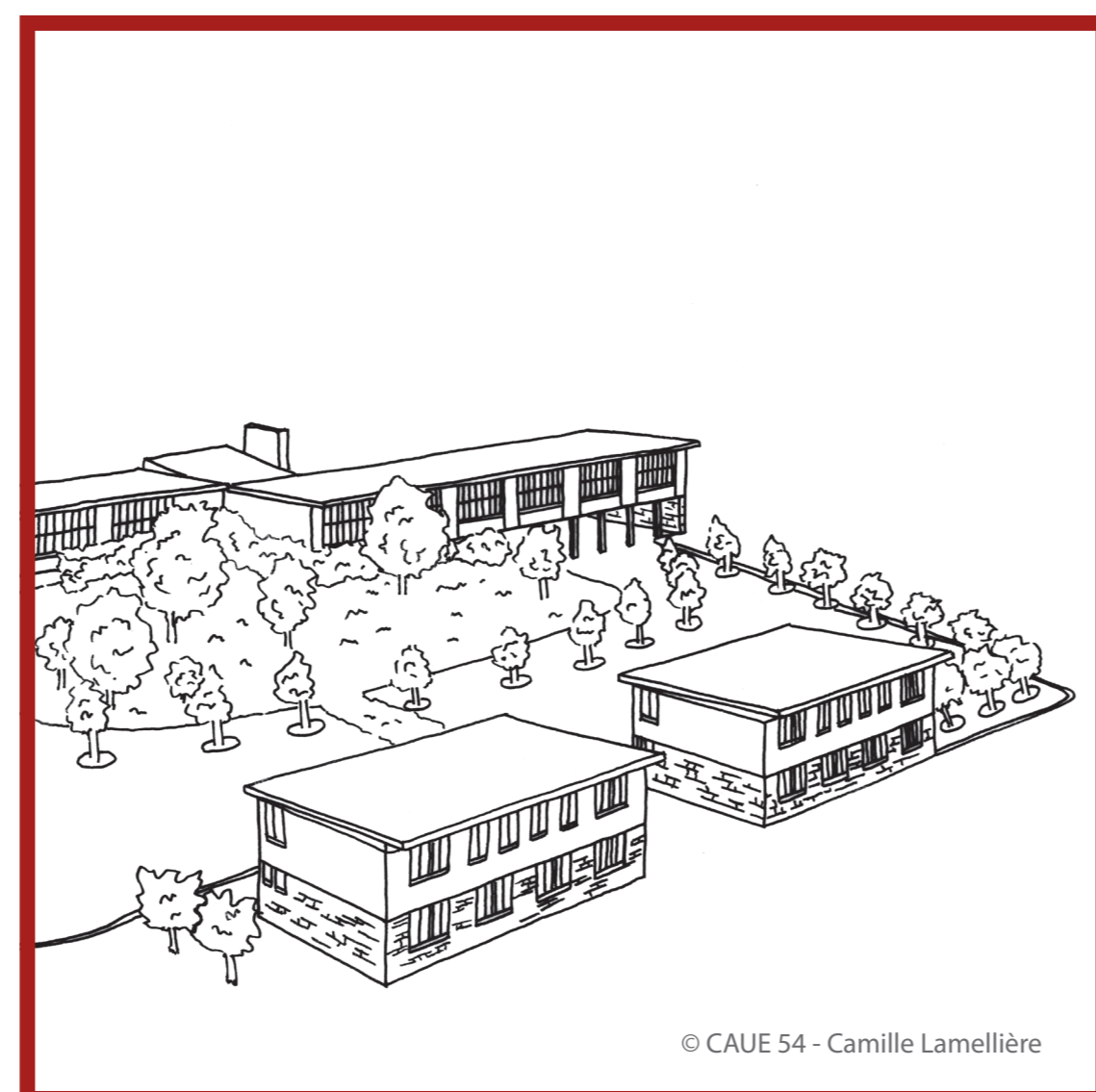
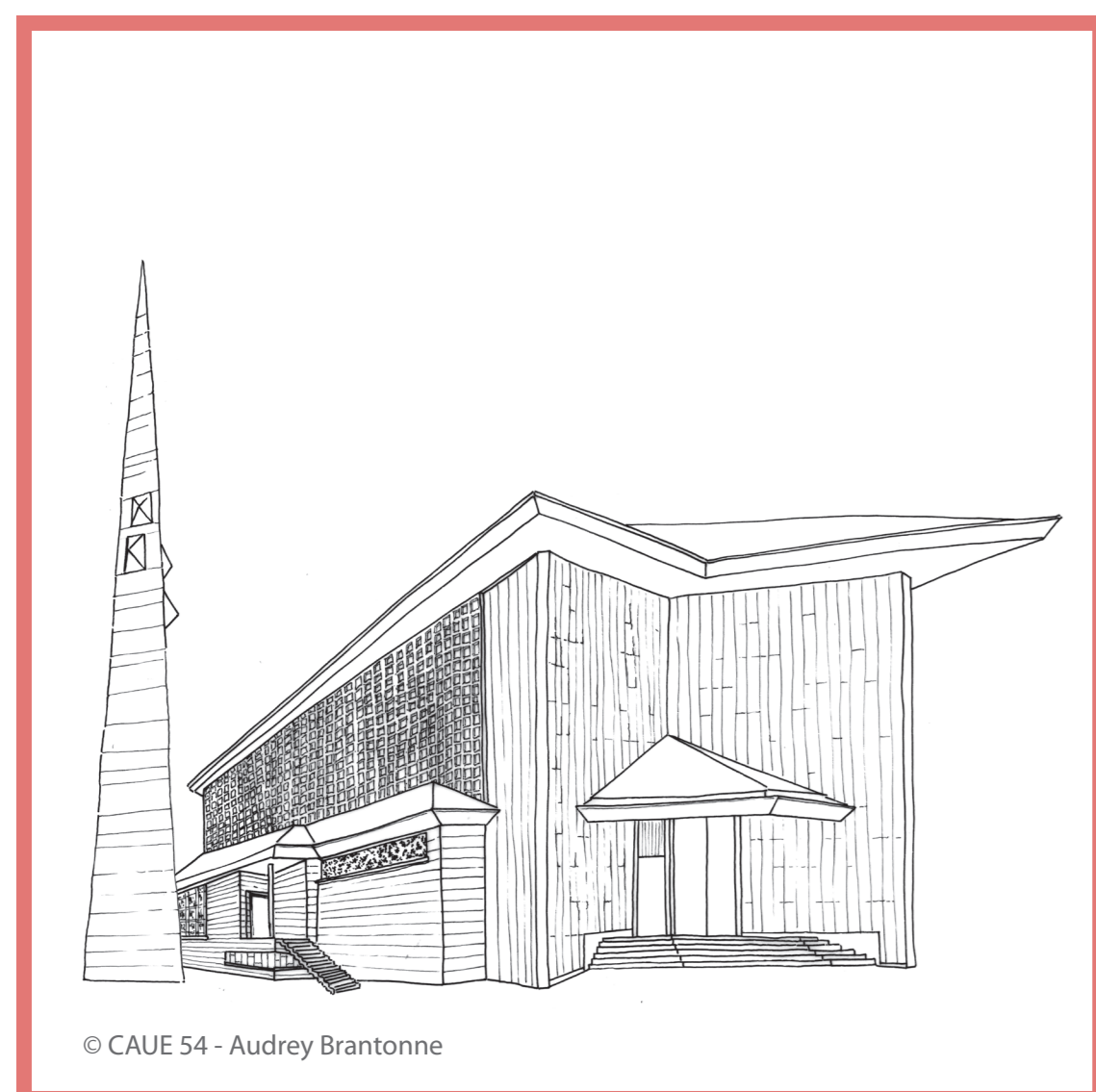

Les caractéristiques de la période

NOUVEAUX
MATÉRIAUX

ZONAGE

ARCHITECTURE
D'URGENCE

EXPÉRIMENTATIONS

1950

2^{NDE} GUERRE MONDIALE

TRENTE GLORIEUSES

SECONDE RECONSTRUCTION ET EXPÉRIMENTATIONS

ARCHITECTURES DE LA CROISSANCE

Les bâtiments

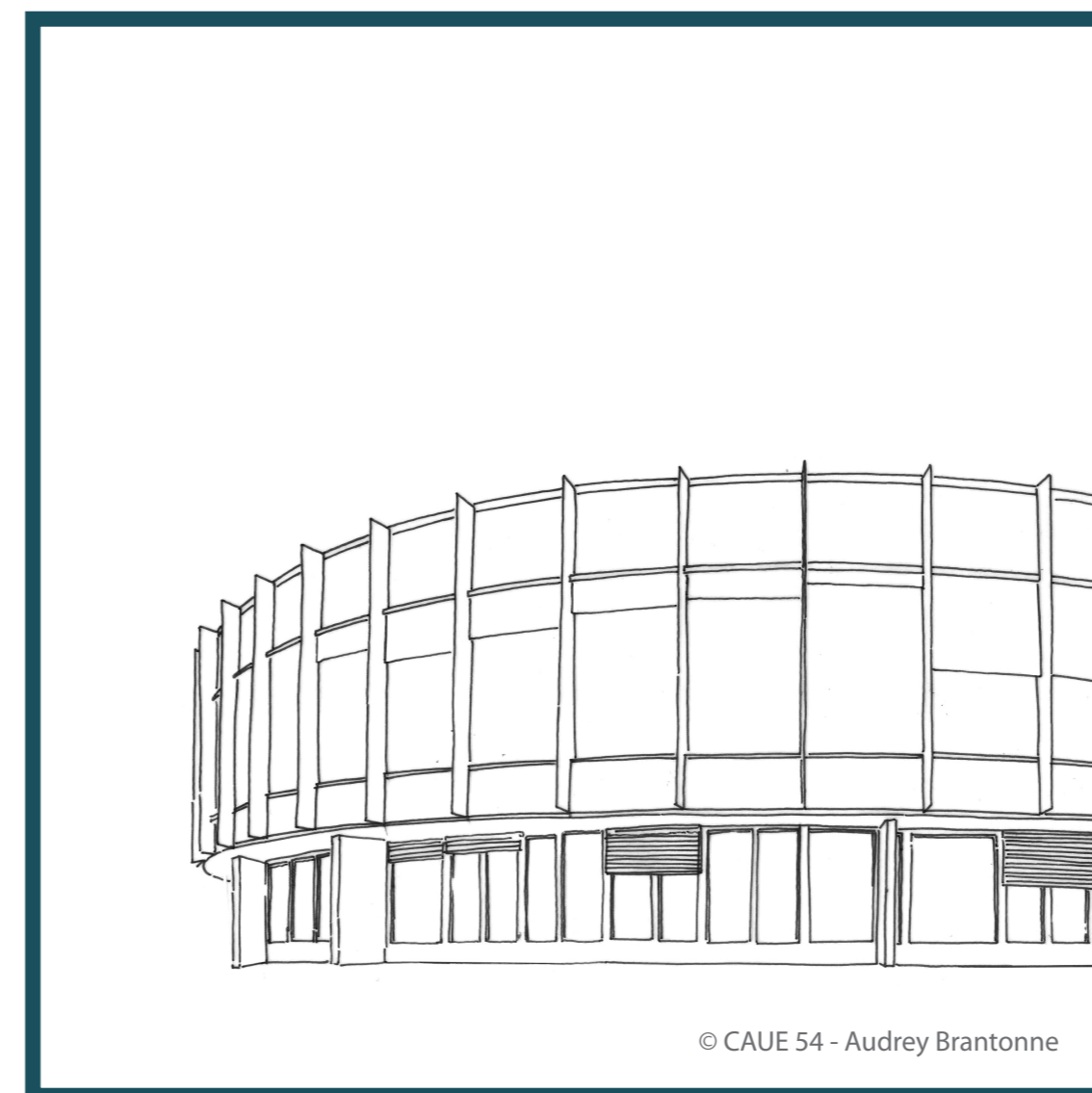
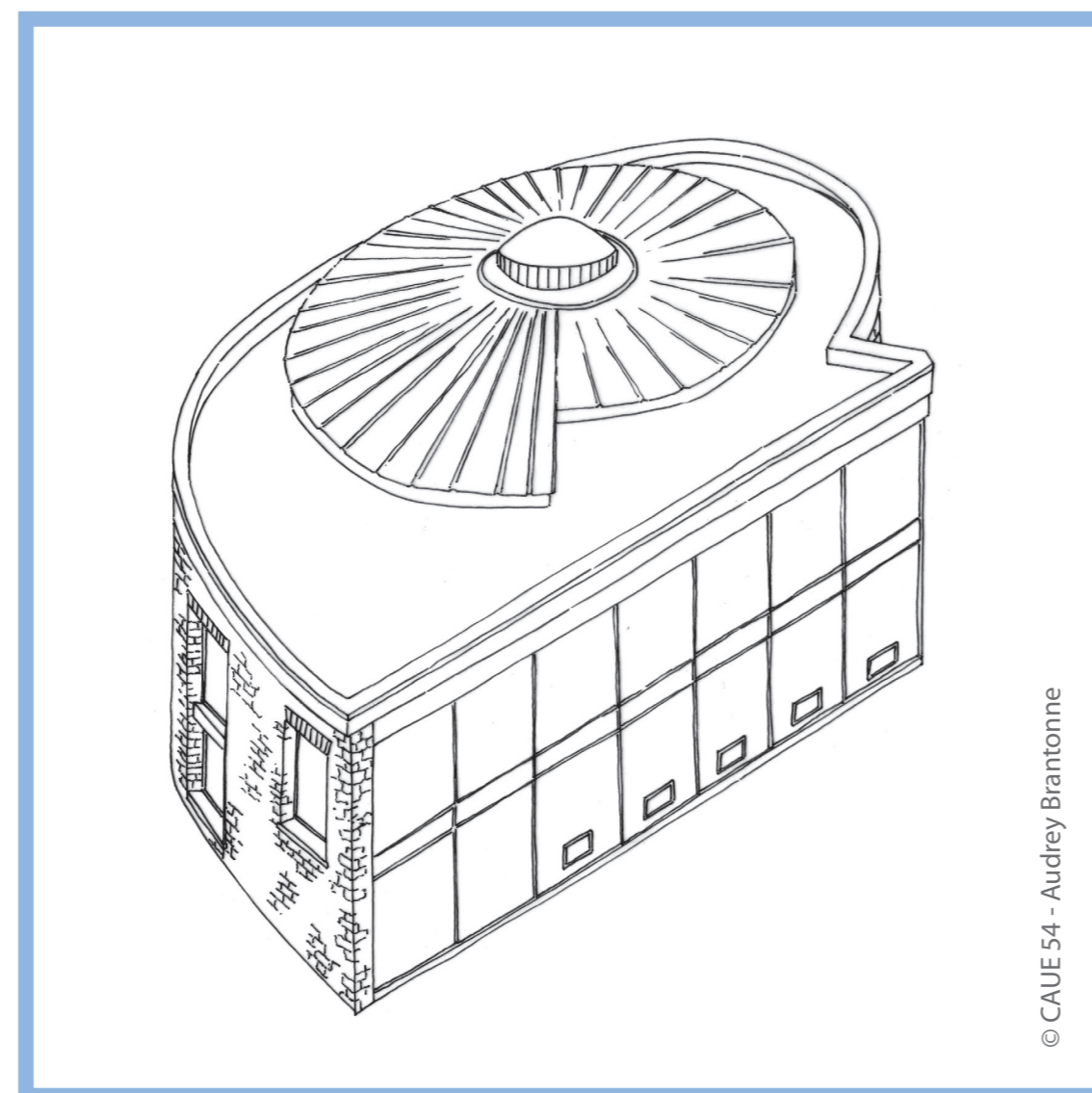
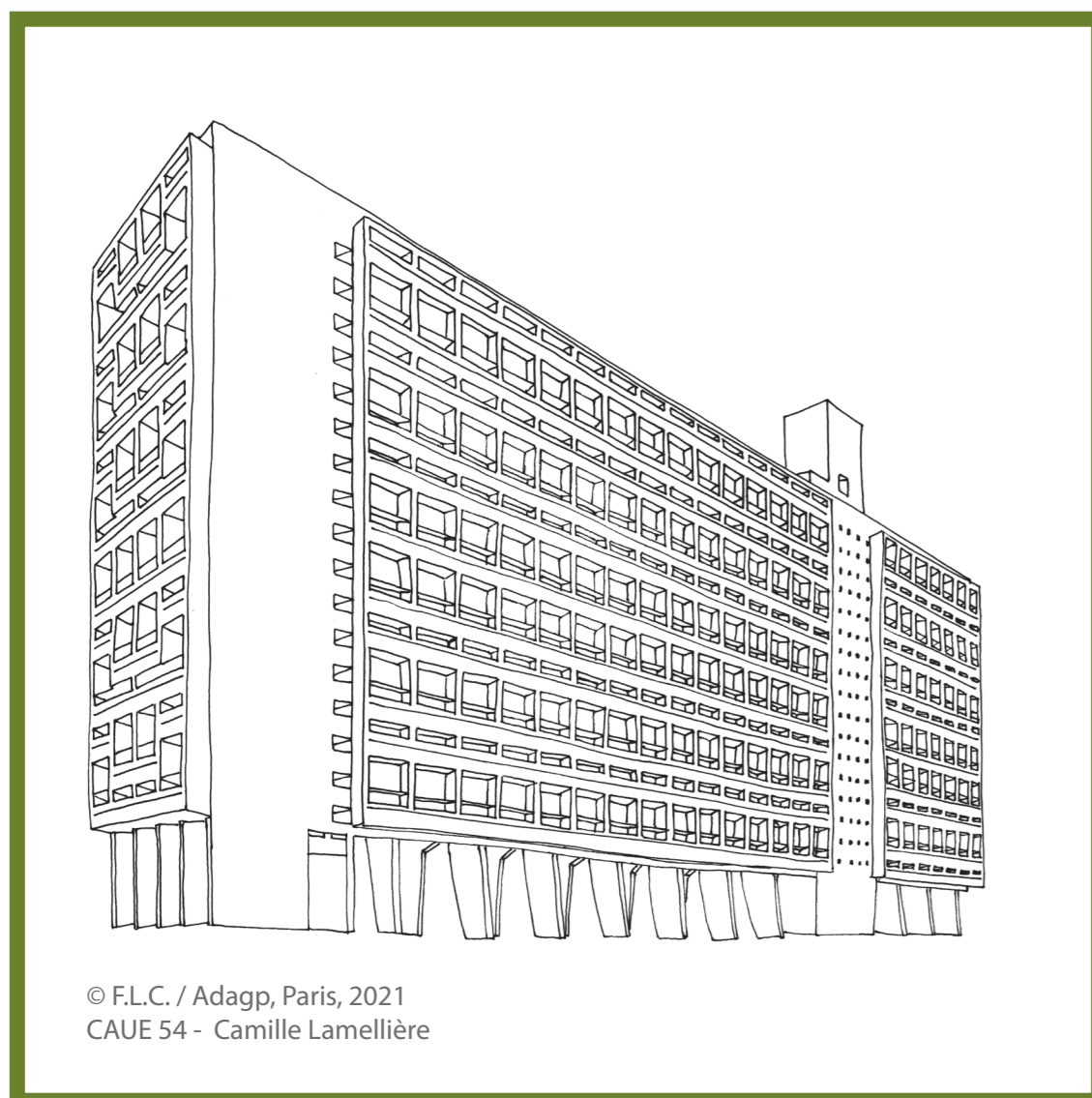
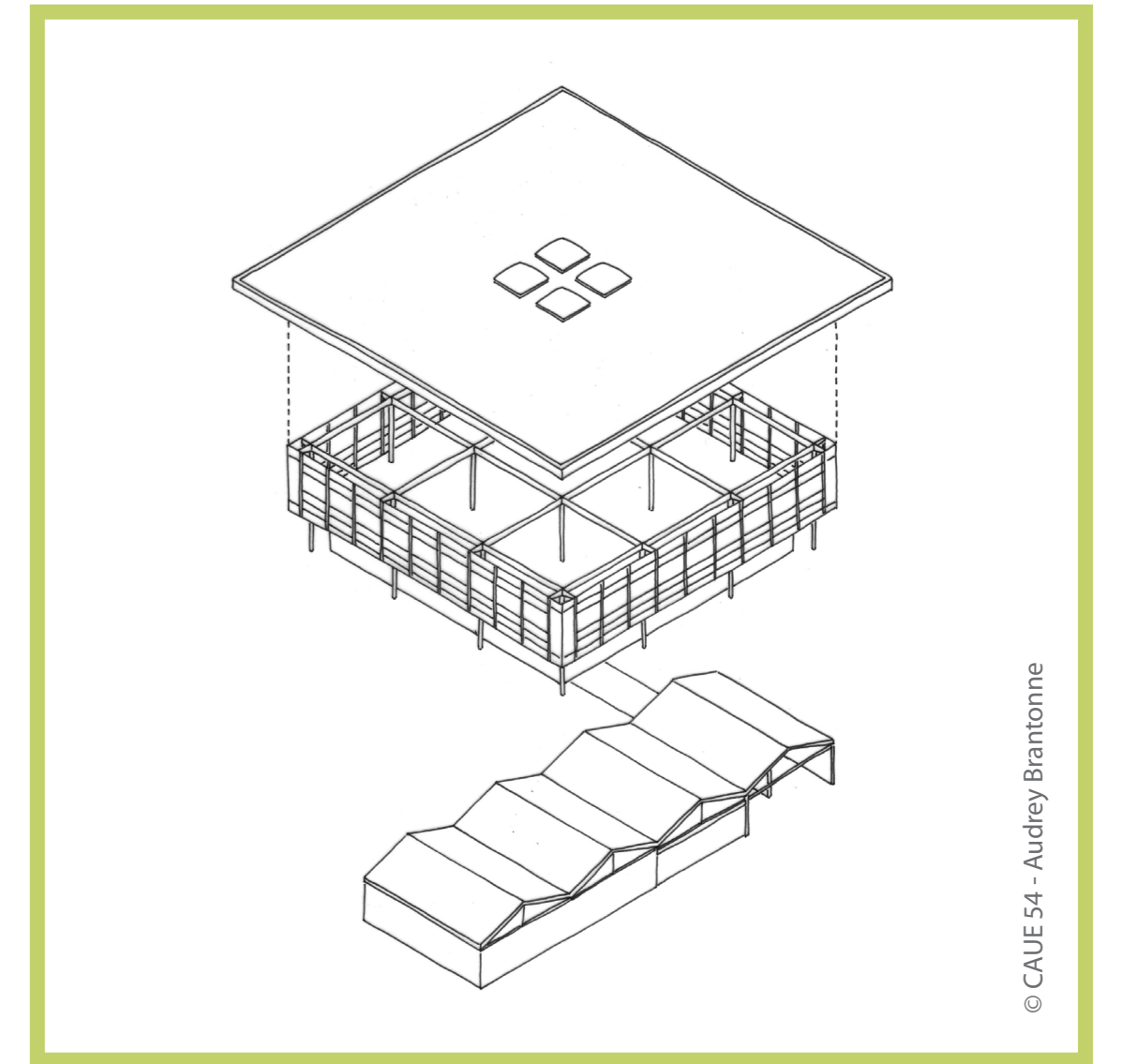
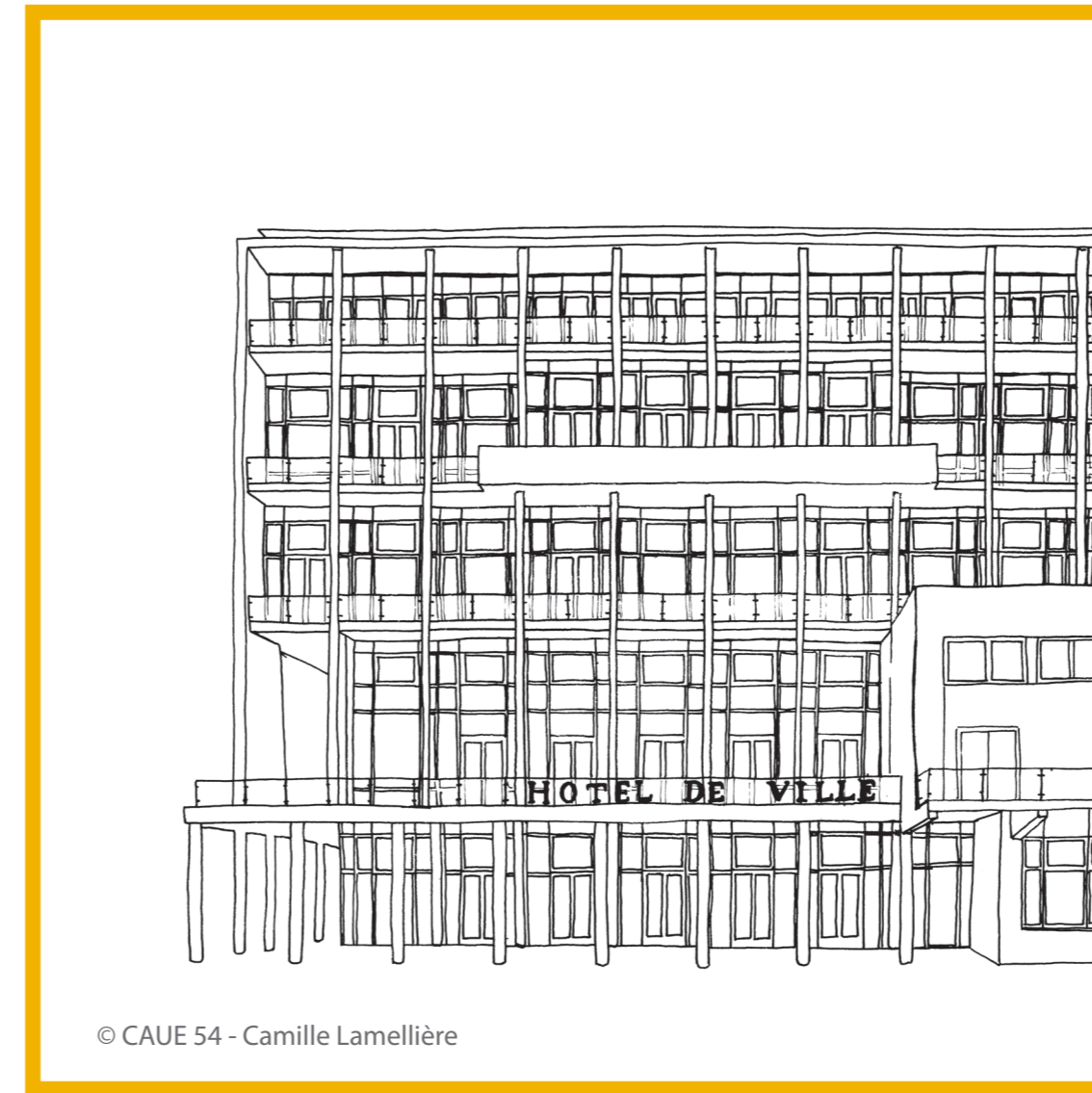
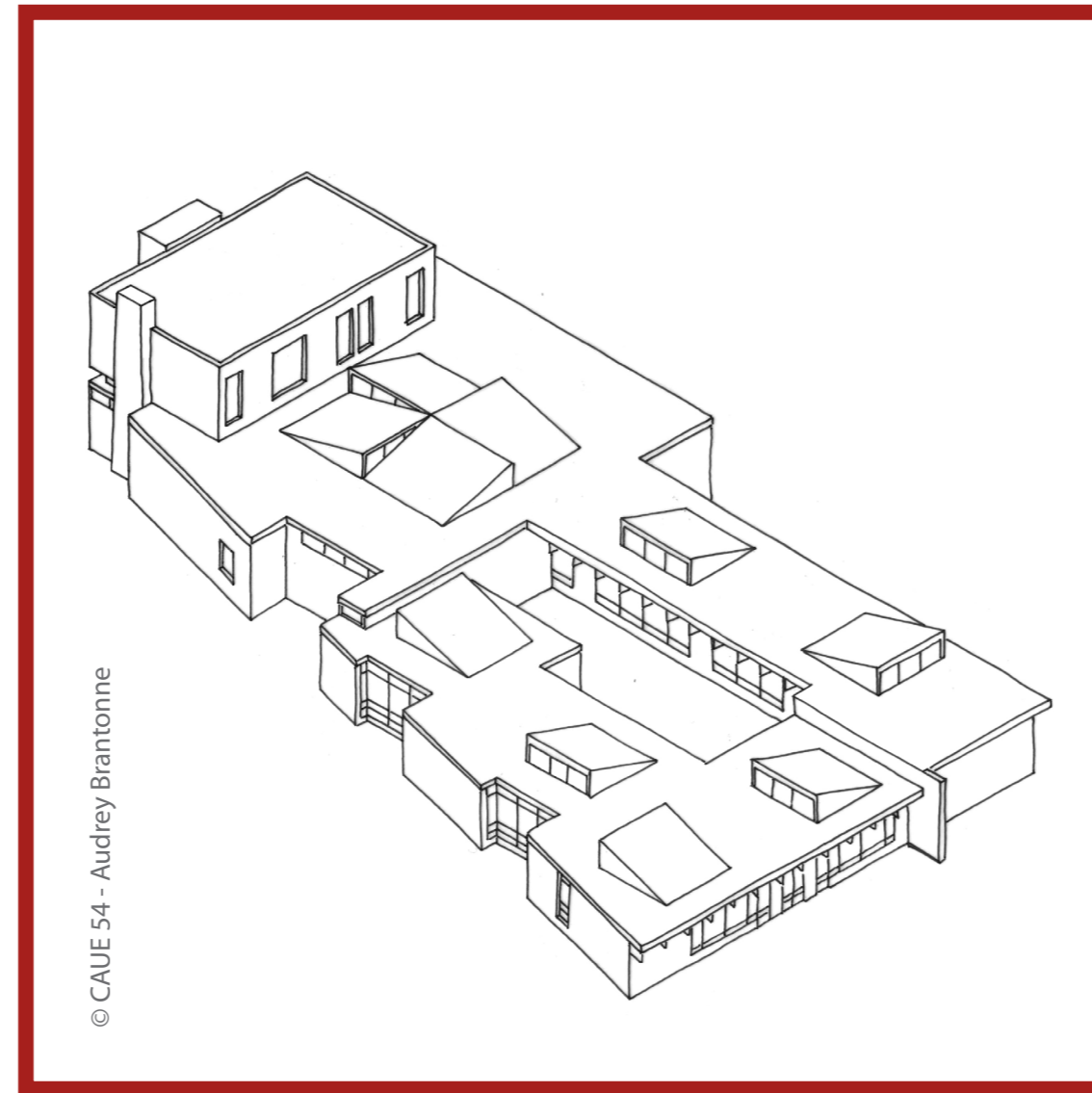
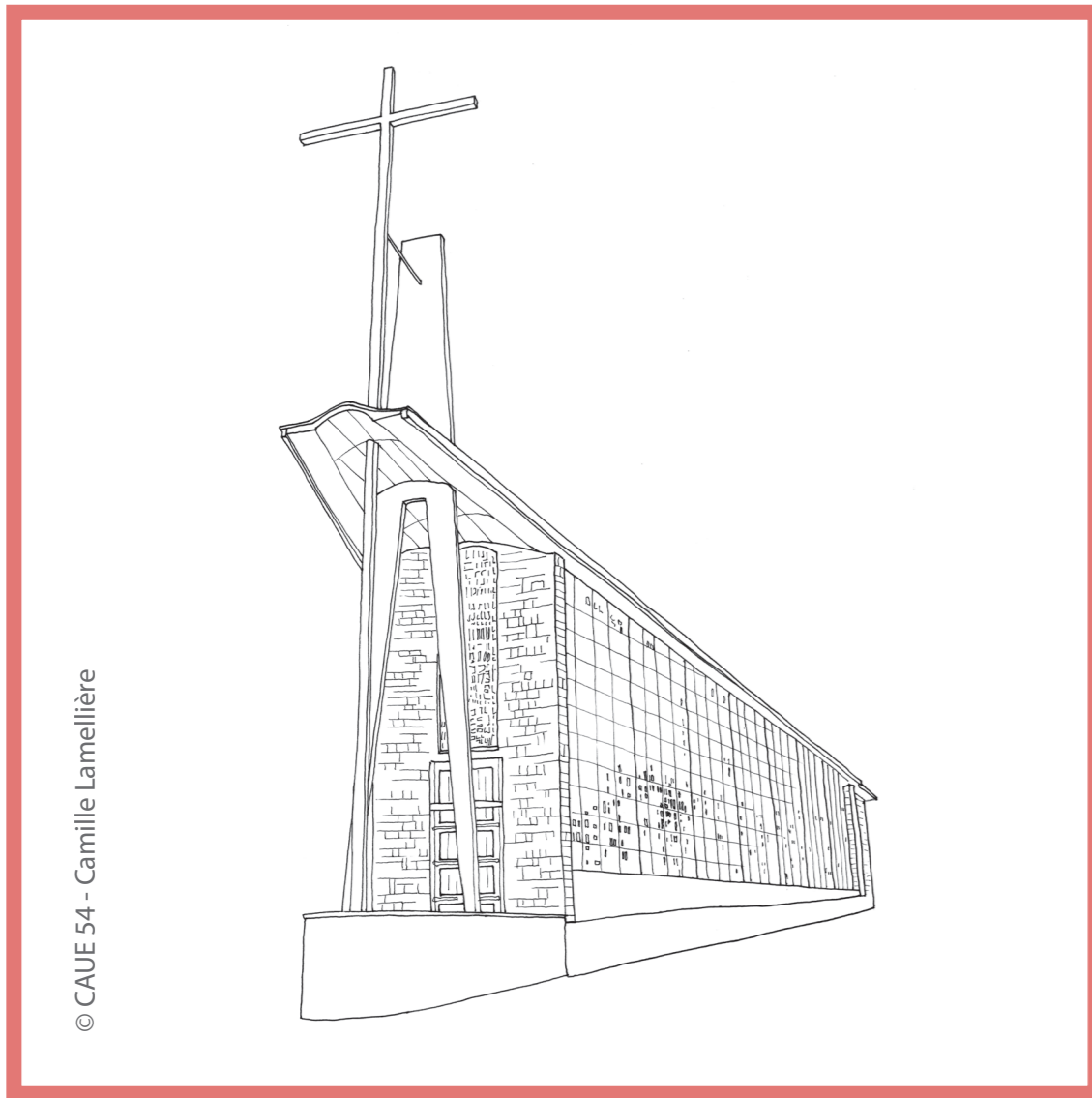

Les caractéristiques de la période

ARCHITECTURE EN
SÉRIE

GRANDS
ENSEMBLES

LOTISSEMENTS

PLASTIQUE,
ALUMINIUM

MUR RIDEAU

SUPERMARCHÉS

1960

1970

ARCHITECTURES DE LA CROISSANCE

DERNIER TIERS DU XX^e SIÈCLE ET POST-MODERNISME

Les bâtiments

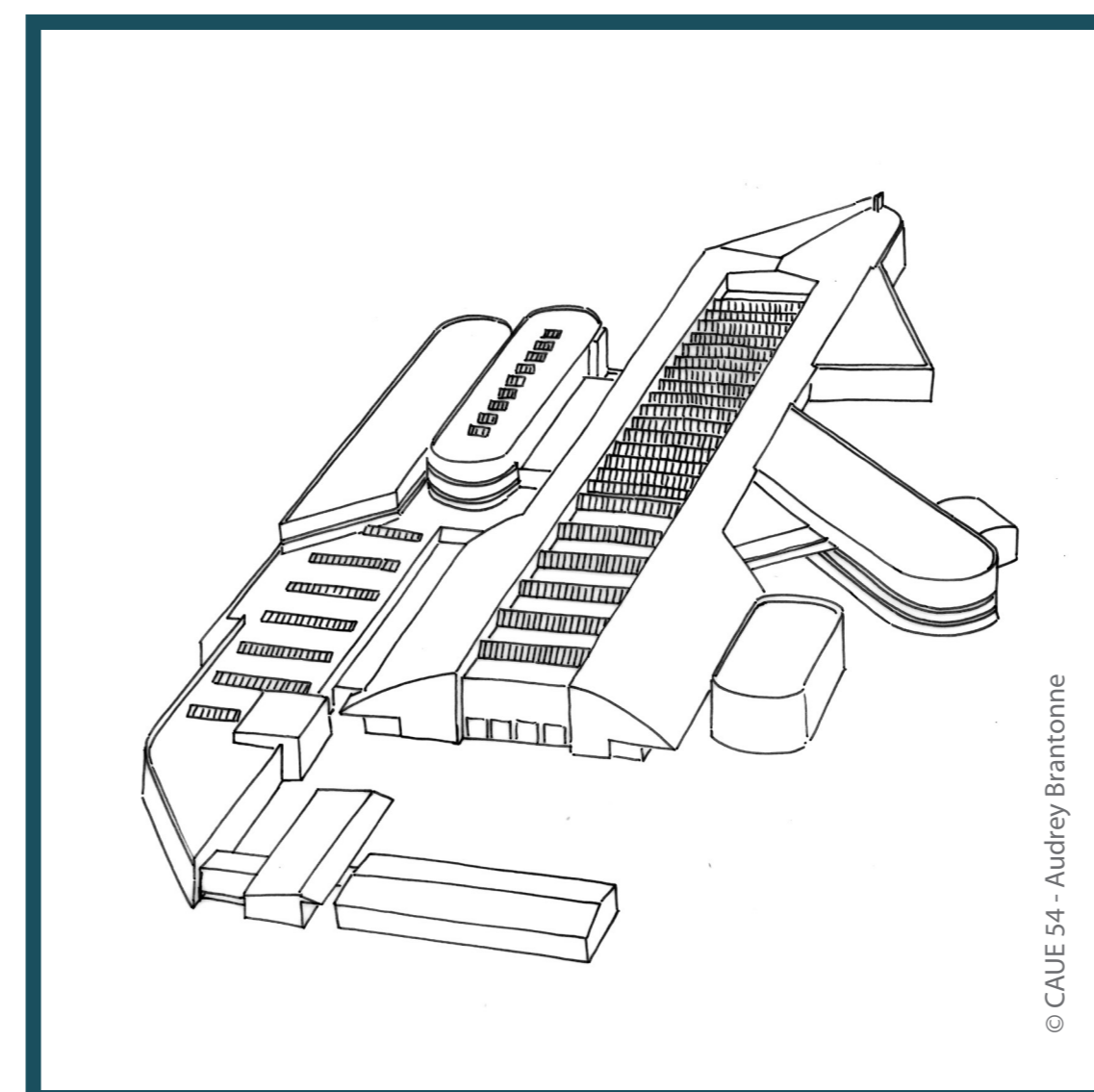
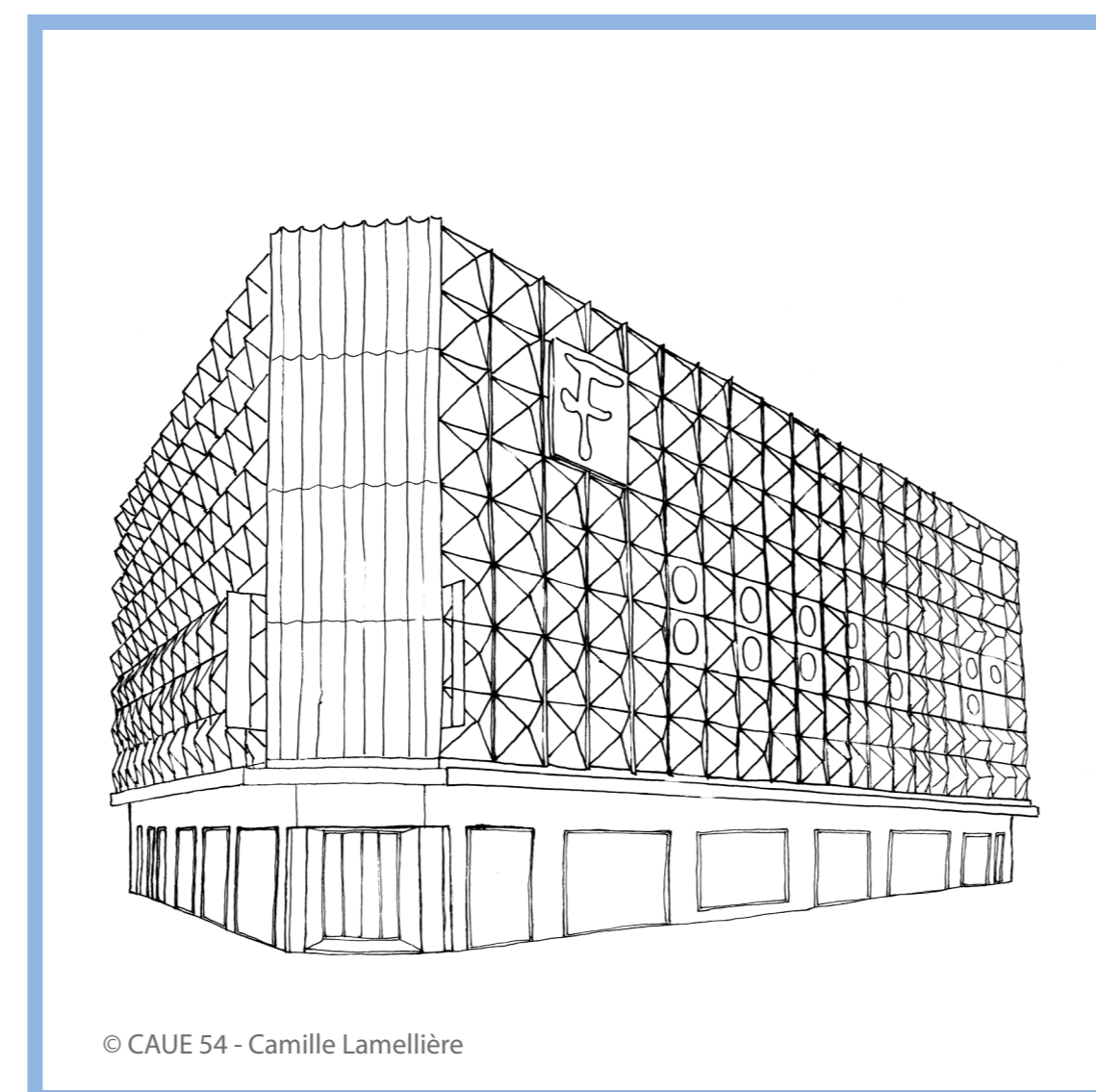
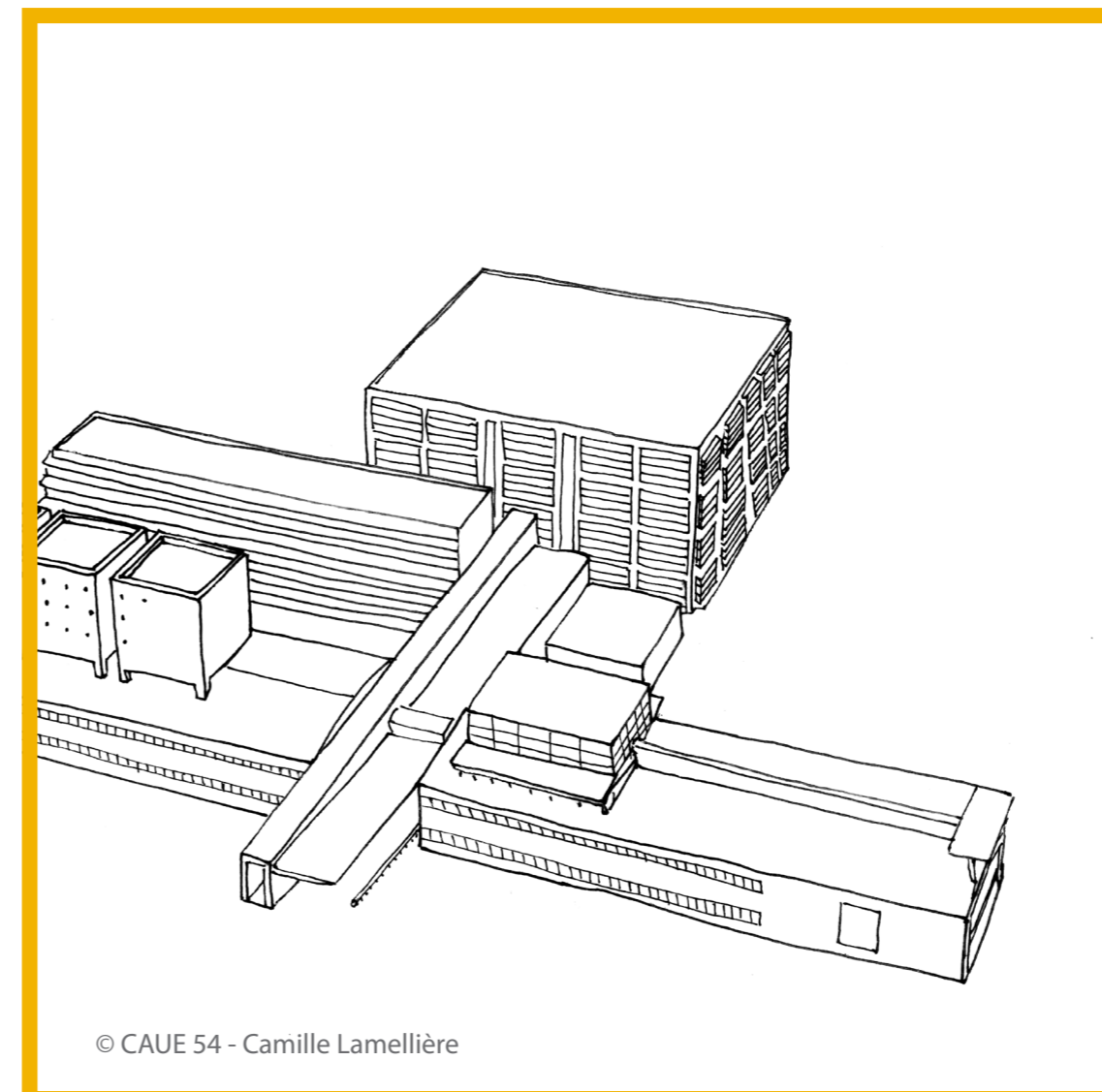
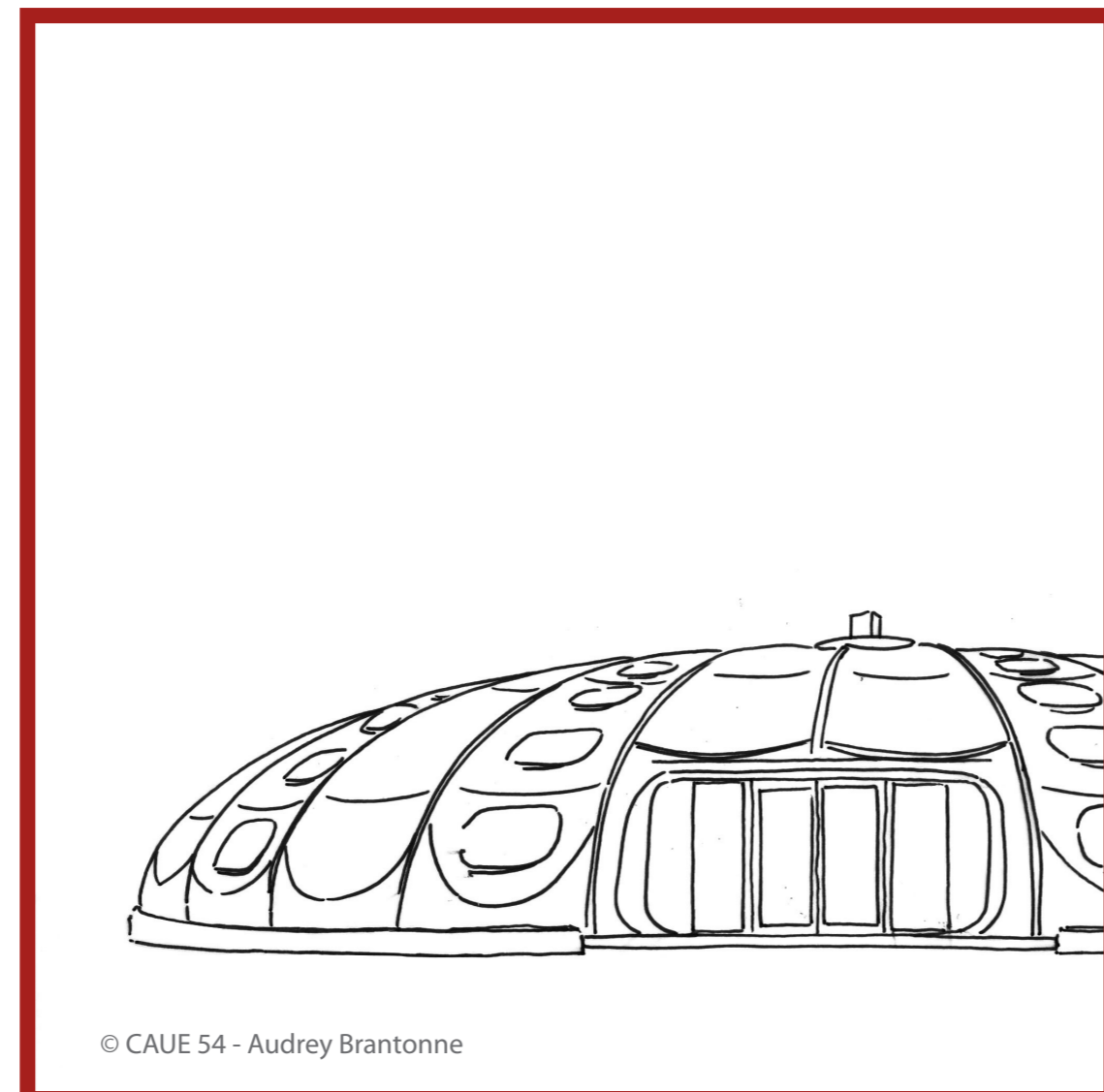
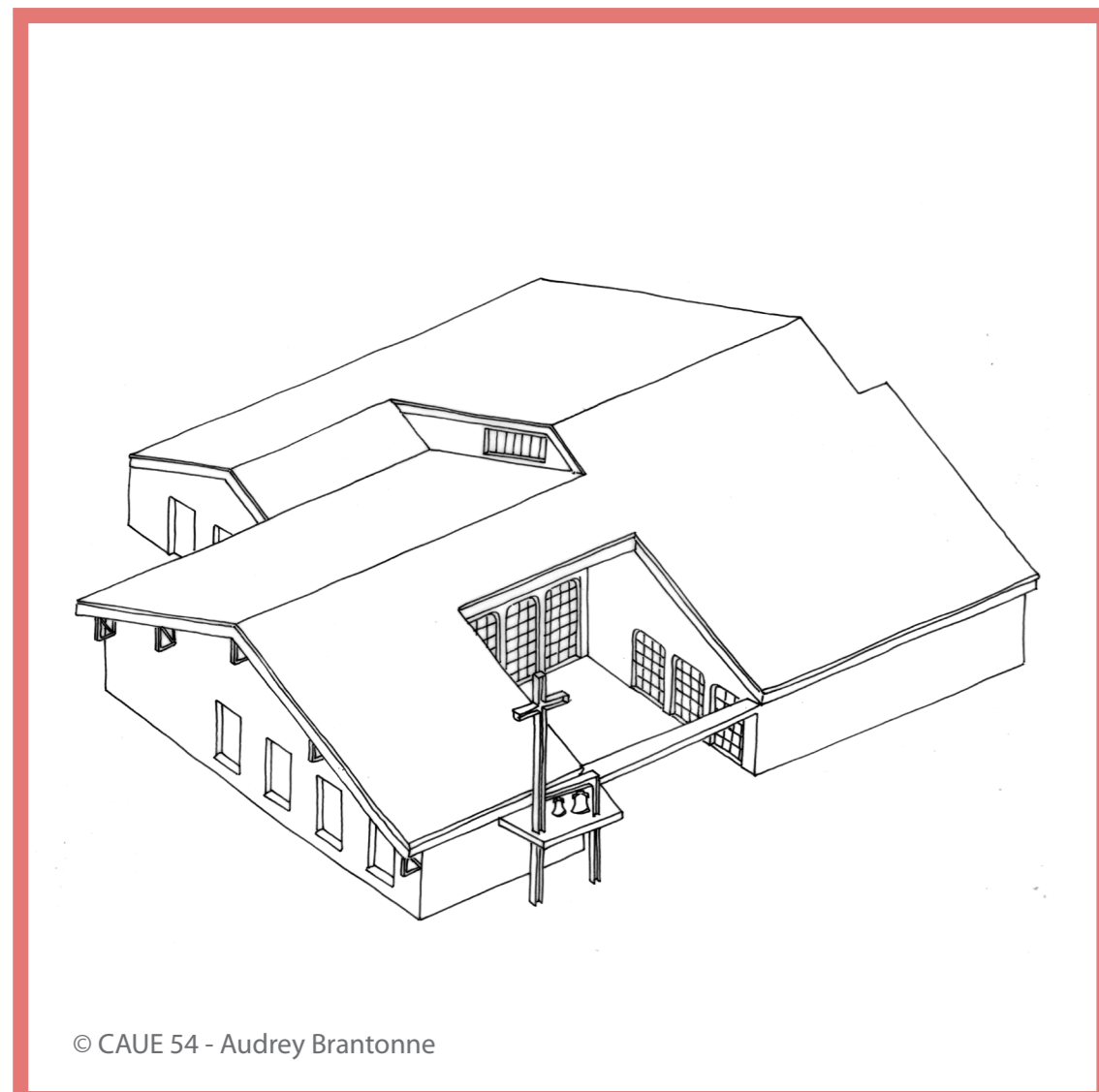

Les caractéristiques de la période

LOTISSEMENTS

ÉCONOMIES D'ÉNERGIE

FORMES GÉOMÉTRIQUES

NÉO-MONUMENT

